

HDP 340 High Pressure Pump series

Design criteria

Hammelmann high pressure pumps are built to operate at the continuous maximum duty stated in the performance parameters. Just compare the crankshaft speed, average plunger speed, plunger diameter and power rating.

High pressure pump

Weight: approx. 1070 kg

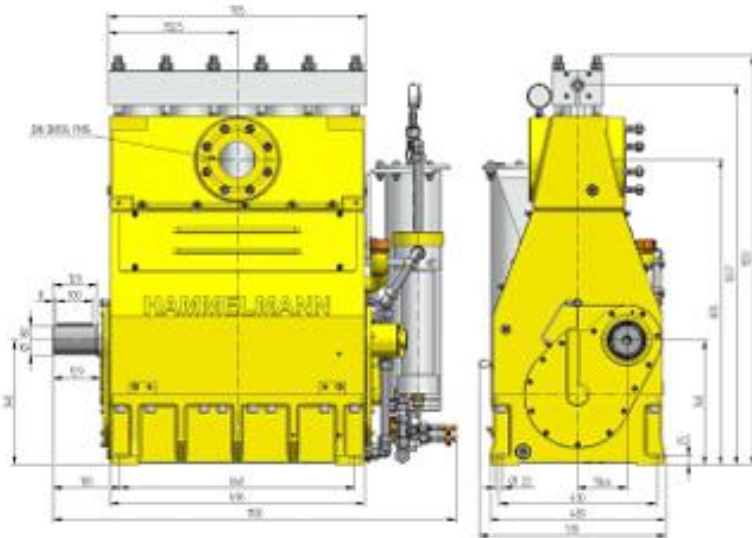

Features

- Power ratings up to 340 kW
- Vertical 5 cylinder design
- Wide variety of complementary ancillaries

Stationary unit with electric motor

Length: 2900 mm
 Width: 1290 mm
 Height: 1750 mm
 Weight: approx. 3800 kg at 340 kW

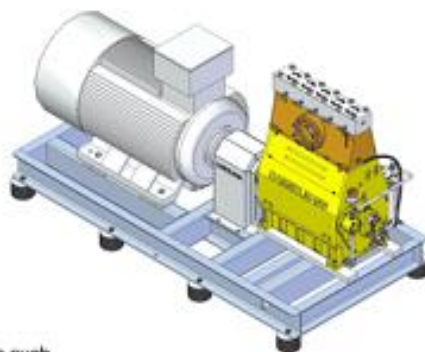

Main dimensions without accessories such as suction line, pressure regulator etc. All shown as right-side drive. Detailed dimensional drawings and weights available on request.

Stationary unit with diesel engine

Length: 3060 mm
 Width: 1570 mm
 Height: 2600 mm
 Weight: approx. 4500 kg with full fuel tank



Quality and reliability

- Crank section calculation by 'Finite element method' ensures long working life under continuous load
- Stainless steel pump head free of alternating stress
- Integral speed reduction gear
- Pressurised oil lubrication system with oil cooler/filter
- Bellows form hermetic seal between the suction chamber and crank section
- Solid ceramic or tungsten carbide plungers
- Choice of application specific seal assemblies
- Choice of bronze (standard) or stainless steel suction chamber



Technical data, series HDP 340

Performance parameters (Standard design)

Note: Actual flow rates for water as pumped medium (volumetric efficiency has already been taken into account).

HDP	Q [l/min]	Required power rating [kW]						D	r. p. m.	
		110	132	200	250	300	340		n 1	n 2
		Operating pressure [bar]								
344	26/24*	2300*	2800*	4200*	4500*			15	1500	411
	31/29*	1920	2300*	3500*	4400*	4500*	1500/1800		493	
	37/35*	1600	1920	2900*	3600*	4400*	1800/2150	591		
	42/40*	1700	2000*	3100*			17,5	1500	411	
	42/40*	1410	1700	2600*	3200*			1500/1800	493	
	51/47*	1180	1410	2100	2700*	3200*	1800/2150	591		
	42/40*	1400	1670	2500*	3000*		19,3	1500	411	
	51/48*	1160	1400	2100*	2600*	3000*		1500/1800	493	
	61/58*	970	1160	1760	2200*	2600*	1800/2150	591		
	46/43*	1300	1550	2400	2800*		20	1500	411	
	55/51*	1080	1300	1960	2500*	2800*		1500/1800	493	
	65/61*	900	1080	1640	2100*	2500*	1800/2150	591		
343	72	830	1000	1510	1800		25	1500	411	
	86	700	830	1260	1570	1800		1500/1800	493	
	103	580	700	1050	1310	1570	1800/2150	591		
	89	660	800	1200	1430		28	1500	411	
	107	550	660	1000	1250	1430		1500/1800	493	
	128	460	550	840	1040	1250	1800/2150	591		
342	101	580	700	1050	1240		30	1500	411	
	122	480	580	870	1100	1240		1500/1800	493	
	146	400	480	730	910	1100	1800/2150	591		
	127	480	570	860	1030		33	1500	411	
	152	400	480	720	900	1030		1500/1800	493	
	182	330	400	600	750	900	1800/2150	591		
	139	420	510	770	910		35	1500	411	
	167	350	420	640	800	910		1500/1800	493	
	200	300	350	530	670	800	1800/2150	591		
	184	320	400	600	700		40	1500	411	
	221	270	320	500	610	700		1500/1800	493	
	265	230	270	410	510	610	1800/2150	591		
	235	260	310	470	550		45	1500	411	
	282	210	260	400	480	550		1500/1800	493	
	338	180	210	320	400	500	1800/2150	591		
	294	210	250	380	450		50	1500	411	
	352	170	210	310	400	450		1500/1800	493	
	422	140	170	260	330	400	1800/2150	591		
	355	170	210	310	370		55	1500	411	
	426	140	170	260	320	370		1500/1800	493	
	511	120	140	220	270	320	1800/2150	591		
	418	140	170	260	310		60	1500	411	
	502	120	140	220	270	310		1500/1800	493	
	602	100	120	180	230	270	1800/2150	591		
491	120	150	220	270		65	1500	411		
589	100	120	200	230	270		1500/1800	493		
706	100	100	160	200	230	1800/2150	591			
569	110	130	200	230		70	1500	411		
683	100	110	160	200	230		1500/1800	493		
819	70	100	130	170	200	1800/2150	591			
744	80	100	150	180		80	1500	411		
892	70	80	120	150	180		1500/1800	493		
1069	60	70	100	130	150	1800/2150	591			

* Ultra high pressure

- Rod force: 88 kN
- Stroke: 75 mm
- Mean piston speed at n2
411 r.p.m. = 1,02 m/sec
493 r.p.m. = 1,23 m/sec
591 r.p.m. = 1,48 m/sec

Typical high-pressure pump units



- Stationary diesel unit in BDF-Container with workshop



- Stationary electric unit



- Electric unit in container



Hammelmann plunger pumps convert 93 to 98 % of the shaft power to hydraulic energy.

D = Piston/Plunger dia. [mm]
n1 = Motor/Engine r.p.m.
n2 = Crankshaft

Hammelmann GmbH
Carl-Zeiss-Straße 6-8
59302 Oelde • Germany
mail@hammelmann.de

Phone (0 25 22) 76-0
Fax (0 25 22) 76-444
www.hammelmann.de

HAMMELMANN®